

C200S Microturbine

High-pressure Natural Gas, ICHP

The Signature Series Microturbine provides reliable electrical/thermal generation from natural gas with ultra-low emissions.



C200S ICHP Microturbine

Electrical Performance⁽¹⁾

Electrical Power Output	200kW
Voltage	400/480 VAC
Electrical Service	3-Phase, 4 Wire Wye
Frequency	50/60 Hz
Electrical Efficiency LHV	33%

Fuel/Engine Characteristics⁽¹⁾

Natural Gas HHV ⁽²⁾	30.7–47.5 MJ/m ³ (825–1,275 BTU/scf)
Inlet Pressure	517–551 kPa gauge (75–80 psig)
Fuel Flow HHV	2,400 MJ/hr (2,280,000 BTU/hr)
Net Heat Rate LHV	10.9 MJ/kWh (10,300 BTU/kWh)

Exhaust Characteristics⁽¹⁾

NOx Emissions @ 15% O ₂	< 9 ppmvd (18 mg/m ³)
Exhaust Mass Flow	1.3 kg/s (2.9 lbm/s)
Exhaust Gas Temperature	280°C (535°F) (Heat Recovery Bypassed)

Benefits

- Ultra-low emissions
- One moving part – minimal maintenance and downtime
- Patented air bearings – no lubricating oil or coolant
- Integrated utility synchronization – no external switchgear
- Internal fuel gas compressor housed within enclosure
- Compact modular design allows for easy, low-cost installation
- Multiple units easily combined – act as single generating source
- Remote monitoring and diagnostic capabilities
- Proven technology with tens of millions of operating hours
- Various Factory Protection Plans available

**Smarter Energy
for a Cleaner Future**

Dimensions & Weight⁽³⁾

Width x Depth x Height	3.0 x 2.5 x 4.0 m (117 x 100 x 157 in)
Weight - Grid Connect Model, dry	6,000 kg (13,200 lbs)
Weight - Dual Mode Model, dry	6,700 kg (14,700 lbs)

Minimum Clearance Requirements⁽⁴⁾

Horizontal Clearance	
Left	1.5 m (60 in)
Right	0.0 m (0 in)
Front	1.7 m (65 in)
Rear	2.2 m (85 in)

ICHP Heat Recovery⁽⁵⁾

Hot Water Heat Recovery	300kW (1.0 MMBtu/hr)
-------------------------	----------------------

Certifications

- UL 2200 Listed
- CE Certified
- Certified to the following grid interconnections standards: UL 1741-SA, VDE, BDEW, CEI 0-16, AS4777
- Compliant to California Rule 21

C200 Engine Components

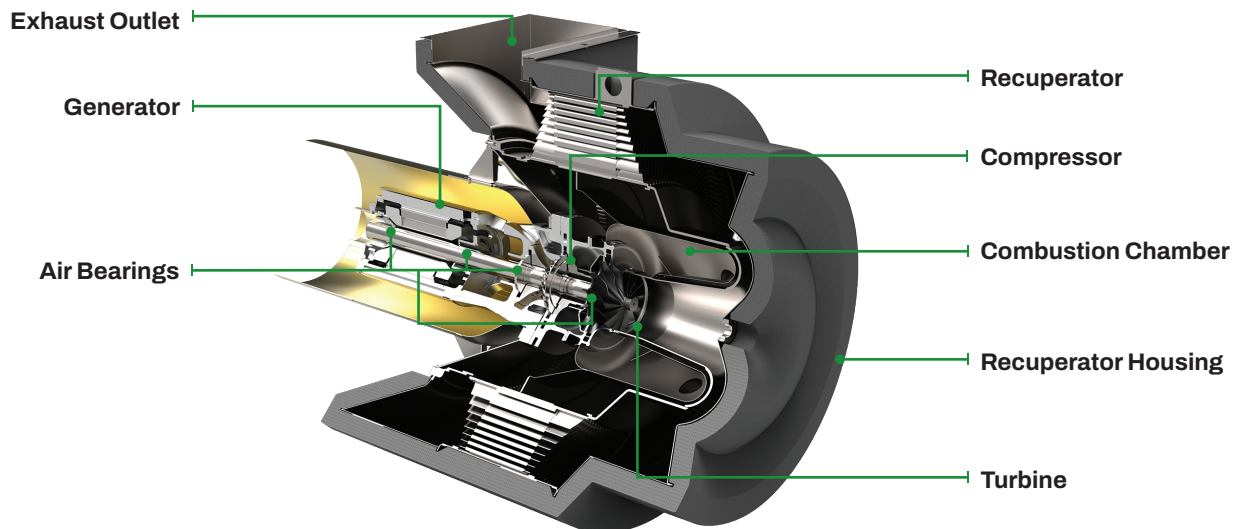

(1) Nominal full power performance at ISO conditions: 15°C (59°F), 14.696 psia, 60% RH
 (2) Suitable for use with fuel blends containing up to 30 percent hydrogen gas by volume
 (3) Approximate dimensions and weights
 (4) Clearance requirements may increase due to local code considerations
 (5) Nominal heat recovery for water inlet temperature of 38°C (100°F) and flow rate of 6.3 l/s (100 gpm)
Specifications are not warranted and are subject to change without notice.