

C600S Power Package

Low-pressure Natural Gas

The Signature Series Microturbine provides 600kW of reliable electrical power in one small, ultra-low emission, and highly efficient package.



C600S Power Package

Electrical Performance⁽¹⁾

Electrical Power Output	570kW
Voltage	400/480 VAC
Electrical Service	3-Phase, 4 Wire Wye
Frequency	50/60 Hz
Electrical Efficiency LHV	31%

Fuel/Engine Characteristics⁽¹⁾

Natural Gas HHV	35.4–42.8 MJ/m ³ (950–1,150 BTU/scf)
Inlet Pressure ⁽²⁾	1.7–34.5 kPa gauge (0.25–5.0 psig)
Fuel Flow HHV	7,290 MJ/hr (6,900,000 BTU/hr)
Net Heat Rate LHV	11.6 MJ/kWh (11,000 BTU/kWh)

Exhaust Characteristics⁽¹⁾

NOx Emissions @ 15% O ₂	< 9 ppmvd (18 mg/m ³)
Exhaust Mass Flow	4.0 kg/s (8.8 lbm/s)
Exhaust Gas Temperature	280°C (535°F)

Benefits

- Ultra-low emissions
- One moving part – minimal maintenance and downtime
- Patented air bearings – no lubricating oil or coolant
- Integrated utility synchronization – no external switchgear
- Internal fuel gas compressor housed within enclosure
- Compact modular design allows for easy, low-cost installation
- High electrical efficiency over a very wide operating range
- High availability – part load redundancy
- Remote monitoring and diagnostic capabilities
- Proven technology with tens of millions of operating hours
- Various Factory Protection Plans available

**Smarter Energy
for a Cleaner Future**

Dimensions & Weight⁽³⁾

Width x Depth x Height	3.0 x 5.8 x 3.0 m (117 x 230 x 119 in)
Weight - Grid Connect Model	12,050 kg (26,600 lbs)
Weight - Dual Mode Model	14,200 kg (31,300 lbs)

Minimum Clearance Requirements⁽⁴⁾

Horizontal Clearance	
Left	1.5 m (60 in)
Right	0.0 m (0 in)
Front	1.7 m (65 in)
Rear	2.2 m (85 in)

Certifications

- UL 2200 Listed
- CE Certified
- Certified to the following grid interconnections standards:
UL 1741-SA, VDE, BDEW, CEI 0-16, AS4777
- Compliant to California Rule 21

C200 Engine Components

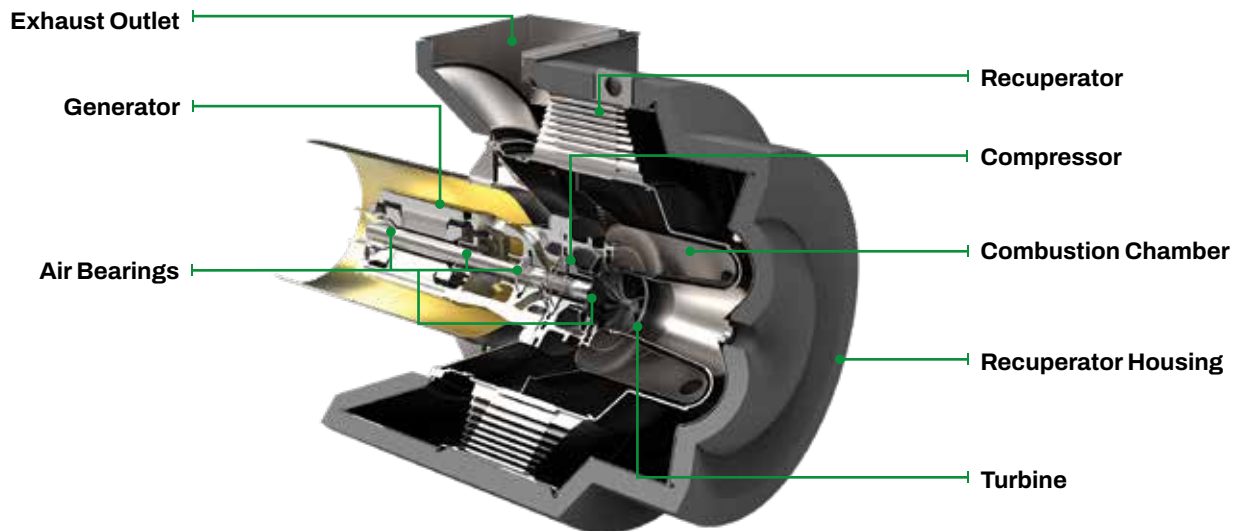

(1) Nominal full power performance at ISO conditions: 15°C (59°F), 14.696 psia, 60% RH

(2) For critical cyclic (on/off) applications, a gas inlet pressure of 5 psig may be a requirement. Consult with Capstone's Application Engineering team

(3) Approximate dimensions and weights

(4) Clearance requirements may increase due to local code considerations

Specifications are not warranted and are subject to change without notice.