

C200S Microturbine

High-pressure Natural Gas



World's largest air-bearing microturbine produces 200kW of clean, green, and reliable power.

- + Ultra-low emissions
- + One moving part – minimal maintenance and downtime
- + Patented air bearings – no lubricating oil or coolant
- + Integrated utility synchronization – no external switchgear
- + Compact modular design allows for easy, low-cost installation
- + Multiple units easily combined – act as single generating source
- + Remote monitoring and diagnostic capabilities
- + Proven technology with tens of millions of operating hours
- + Various Factory Protection Plans available



C200S Microturbine

Electrical Performance⁽¹⁾

Electrical Power Output	200kW
Voltage	400/480 VAC
Electrical Service	3-Phase, 4 Wire Wye
Frequency	50/60 Hz
Electrical Efficiency LHV	33%

Fuel/Engine Characteristics⁽¹⁾

Natural Gas HHV	30.7–47.5 MJ/m ³ (825–1,275 BTU/scf)
Inlet Pressure	517–551 kPa gauge (75–80 psig)
Fuel Flow HHV	2,400 MJ/hr (2,280,000 BTU/hr)
Net Heat Rate LHV	10.9 MJ/kWh (10,300 BTU/kWh)

Exhaust Characteristics⁽¹⁾

NO _x Emissions @ 15% O ₂	< 9 ppmvd (18 mg/m ³)
Exhaust Mass Flow	1.3 kg/s (2.9 lbm/s)
Exhaust Gas Temperature	280°C (535°F)

Dimensions & Weight⁽²⁾

Width x Depth x Height ⁽³⁾	3.0 x 2.5 x 2.9 m (117 x 100 x 114 in)
Weight - Grid Connect Model	5,200 kg (11,400 lbs)
Weight - Dual Mode Model	5,850 kg (12,900 lbs)

Reliable power when and where you need it. Clean and simple.

Minimum Clearance Requirements⁽⁴⁾

Horizontal Clearance	
Left	1.5 m (60 in)
Right	0.0 m (0 in)
Front	1.7 m (65 in)
Rear	2.2 m (85 in)

Certifications

- UL 2200 Listed
- CE Certified
- Certified to the following grid interconnection standards: UL 1741, VDE, BDEW and CEI-16
- Compliant to California Rule 21

C200 Engine Components

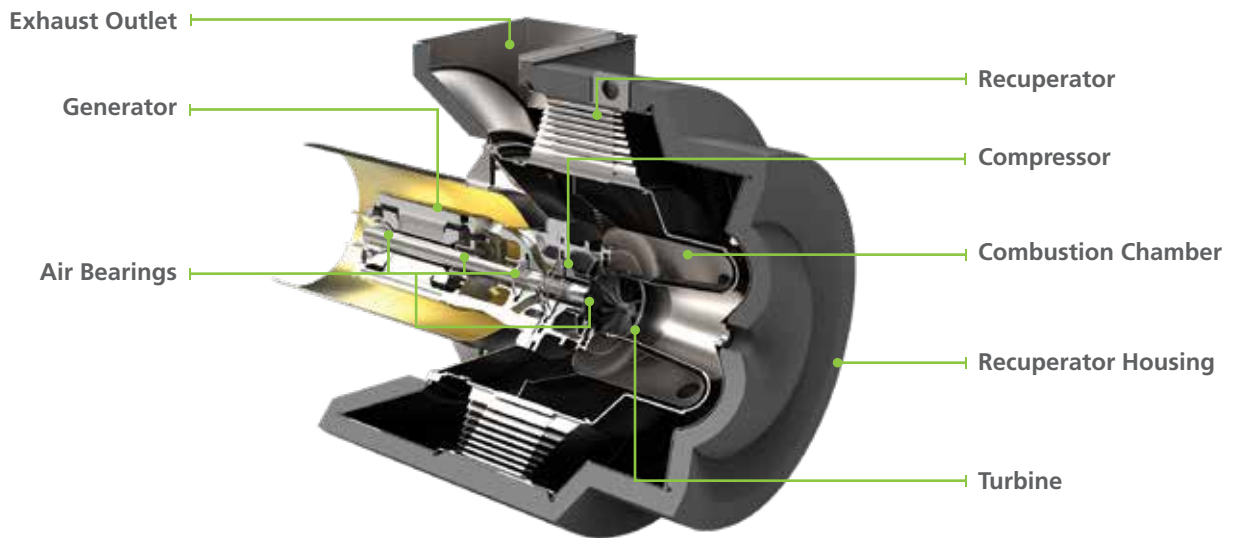

(1) Nominal full power performance at ISO conditions: 15°C (59°F), 14.696 psia, 60% RH
 (2) Approximate dimensions and weights
 (3) Height dimensions are to the roofline. Exhaust outlet extends at least 0.13 m (5 in) above the roofline
 (4) Clearance requirements may increase due to local code considerations
 Specifications are not warranted and are subject to change without notice.

